

Frankfort-Elberta Area Schools
District Technology Plan

**613 Leelanau Ave.
Frankfort, MI 49635
Supt. Tom Stobie (231)352-4641
District Code: 10025**

**Traverse Bay Area ISD
ISD Code #28**

Locate our school web site at:

<http://www.frankfort.k12.mi.us>

The district Technology Plan is located at:

http://www.frankfort.k12.mi.us/tech_plan.html

**November 2011
Next State Review: August 2015
Contact Person:
District Technology Coordinator
Michael Tiesworth
(231)352-7601 ext 306
mtiesworth@frankfort.k12.mi.us**

Table of Contents

Page 3	Technology Plan Summary
Page 3	A. Technology Vision Statement
Page 3-4	B. Organization
Page 4-5	C. Acceptable Use Policy
Page 5-12	D. Technology Curriculum
Page 12	E. Applying Technology to Other Subjects
Page 13	F. Staff Development
Page 13	G. Technical and Other Supporting Resources
Page 13-14	H. Goals and Evaluation
Page 15	Evaluation Table
Page 15	Student Evaluations
Page 15-16	I. Software
Page 16-17	J. Hardware Inventory and topology
Page 18	K. Interoperability
Page 18	L. Community Relations and Parental Communications
Page 18-19	M. Funding
Page 19	N. Budget
Page 19	O. Technology School Improvement Strategies for 2011 – 2015
Page 20	Summary

Technology Plan Executive Summary

This updated District Technology Plan for Frankfort-Elberta Area Schools was originally written in the spring of 2002 and updated in the summer of 2011 as required by state and federal legislation. This process is undertaken to ensure that the implementation of technology into the district continues in a consistent, thoughtful fashion.

The District Technology Plan for Frankfort-Elberta Area Schools seeks to provide a framework for decision making concerning technology in the district. By including references to the district curriculum, the state core curriculum, and the district's strategic plan, the District Technology Plan includes the key information for this process. References to budget considerations also are included so that there is a realistic approach to implementation of technology, that is, the plan is not designed to provide a "pie in the sky" approach with unreachable objectives. Rather, the plan attempts to continue to offer a course of action that is "doable" based on resources available in the district.

A. Technology Vision Statement

It is the vision of the Frankfort-Elberta Area Schools that we provide our students with the technological tools necessary to live in a world that is reliant on technology.

Technology Vision Goals:

1. Provide learners of all ages continuous access to local and global information through on-going availability of current technologies.
2. Support employee development to ensure technological competency.
3. Expand the teacher's role as lead learner and as facilitator. This will result in:
 - a. Self directed learners.
 - b. Creative problem solvers.
 - c. Effective use of time and resources.
 - d. Understanding of our global interdependence.
4. Provide a competitive edge for our school district and learners in the market place.

B. Organization

Ultimately, it is the need for teaching and learning by the students, staff, parents, and community, which drives the implementation and use of technology. In order to insure that the end users experience appropriate technology and its effective use in the Frankfort-Elberta Area Schools, it is a current goal that the following organization is established.

1. Building Technology Teams — Each building in the district is to determine a staff member that will be assigned as tech teacher at their respective school. These team leaders will also work with the Building Curriculum Teams to coordinate the technology goals with the curriculum goals.
2. Technology Assisting Student – Available and interested students will be used to assist the technology coordinator in troubleshooting computer issues in both the Elementary and High School.

C. Acceptable Use Policy

CONDITIONS, RULES, and ACCEPTABLE USE POLICY

The Frankfort-Elberta Area School District has actively pursued making advanced technology and increased access to learning opportunities available to our students and staff. The Internet is a part of this information "superhighway." We believe this computer technology will help propel our school into the Information Age by allowing students and staff to access and use information sources from district computers. It will help communicate and share information with individuals or groups of other students and staff. The Internet is a tool for lifelong learning.

PROPER AND ETHICAL USE

With this learning tool students and staff must understand and practice proper and ethical use. All students and staff must attend training regarding procedures, ethics, and security involving using the Internet before receiving an account name and password in order to use the system.

CONDITIONS AND RULES FOR USE

*Acceptable Use

The purpose of the Internet is to facilitate communications in support of research and education by providing access to unique resources and an opportunity for collaborative work. To remain eligible as a user, the use of the account must be in support of and consistent with the educational objectives of the District.

*Filtering

In conjunction with the Children's Protection Act, Frankfort-Elberta Area Schools has implemented a filter software that is run at the TBAISD level to prevent viewing of inappropriate sites that may impact students in a negative way. (NetSweeper) Any sites that the district deems as distracting to the learning process (games) may also be filtered. All sites that allow downloading will be filtered on an "as needed basis" to prevent slow down of network traffic.

*Privilege

The use of the Internet is a privilege, not a right. Inappropriate use, including any violation of these conditions and rules, may result in the cancellation of this.

A RESPONSIBLE USER

A responsible user of the Internet may keep an account as long as the user is a staff member or student in the Frankfort-Elberta Area School District.

A responsible user may:

- Use the Internet to research assigned classroom projects.
- Use the Internet to send electronic mail (email) to other users only when corresponding on school projects.
- Use the Internet to explore other computer systems.

A responsible user:

- May NOT use the Internet for any illegal purpose.
- May NOT use impolite or abusive language.
- May NOT violate the rules of common sense of etiquette.
- May NOT change computer files that do not belong to the user.
- May NOT receive copyrighted material without permission.

Note that all Frankfort-Elberta School system operators will have access to all user accounts, including email.

By signing this agreement you acknowledge that you:

- Understand the rules and regulations of the Frankfort-Elberta School Acceptable Use Policy (this document).
- Realize that if the rules are violated your privileges will end.
- Understand there will be no second chances.

STUDENT SIGNATURE AND PARENTAL CONSENT FORM

Frankfort-Elberta School Internet Account

(Note: if the student is too young to read the Acceptable Use Policy, please provide assistance. The purpose of the Acceptable Use Policy is to provide information, not to exclude anyone.)

Student's last name: _____

Student's first name: _____

School name: _____

If I follow the rules I can continue to use the Internet. If I do not follow the rules in this Acceptable Use Policy, I understand that my Internet privileges will be taken away from me. I understand that there are no second chances.

Student Signature: _____

Date of Signature: _____

PARENTAL CONSENT

I have read the Frankfort-Elberta School Acceptable Use Policy. I understand that the Internet is a worldwide group of hundreds of thousands of computers. I know that the Frankfort-Elberta School does not control the content of these Internet networks. When using the Internet, I realize students may read material that I might consider controversial or offensive. The Frankfort-Elberta School has my permission to give an Internet account to my child. I understand that my child may keep this address as long as procedures described in the Acceptable Use Policy are followed.

Parent of guardian Signature: _____

Date of Signature: _____

D. Technology Curriculum

The Frankfort-Elberta Area Schools educational community recognizes that technology is primarily a tool to be used for learning and acquiring other skills and competencies. With this recognition in mind new technologies must be considered for their practical applications in teaching and learning curricular skills and competencies prior to their introduction, utilized to teach those particular curricular skills and competencies after their introduction, and evaluated for their effectiveness in teaching those particular curricular skills and competencies after they are in use. The process for integration into the curriculum will follow the curriculum development process of the district including curriculum analysis, curriculum revision, and curriculum evaluation.

In the Frankfort-Elberta Elementary school the computer instructor offers each grade instruction in skills and the use of computers. Each class is scheduled for once or twice a week - sometimes in the classroom and sometimes in the computer lab. About three fourths of the students have computers at home and they are often ahead of the curriculum in the early grades. These students help other students who have less experience.

In grades kindergarten to three the technology goals and subject matter goals reinforce one another. Students use popular drill and practice programs to reinforce lessons in reading, math and science. These include keyboard and mouse coordination games, the use of Microsoft Paint and Microsoft Word to express themselves through art and language. And the beginning of keyboarding. To operate these programs the students practice some of the simple technology skills dealing with the operation of the keyboard and mouse. They learn how to start a program from the desktop, make choices on the screen using the mouse or keyboard and finally exit a program.

Kindergarten

The student will :

1. Point to mouse, keyboard, monitor, speakers, headphones, printer, CD drive.
2. Use the mouse to start a program, make choices in the program using the mouse and keyboard and exit the program. The student will avoid indiscriminate mouse clicking and will seek help from teacher or another student when necessary.
3. Observe proper care of equipment and courtesy in using the computer.

Applications:

1. In the Paint program draw a rectangle, circle, and triangle.
2. Utilize desktop software and internet sites to compliment beginning letters and sounds.

First Grade

The Student will:

1. Be able to login to the Windows Server with assistance.
2. Be able to navigate through simple internet sites independently.

Applications:

1. Internet Explorer pre-approved websites
2. Read Naturally
3. Raz Kids
4. Microsoft Word, simple paragraphs
3. Microsoft Paint

Second Grade

The Student will:

1. Use the shift, or cap locks to capitalize letters. (*Microsoft Word*)
2. Use the period key and question mark.
3. Type numbers on keypad or keyboard.
4. Type a sentence.
5. Print a document.
6. Students will be able to login to the Windows Server with little assistance.

Applications:

1. Use *Microsoft Word* to write sentences related to subjects.
2. Observe operation of Internet in teacher demonstration and conduct a search for information in a highly structured search on mammals.
3. Read Naturally
4. UltraKey
5. Google Earth

Third Grade

The student will:

1. Use the menu bar functions on word processor (*Microsoft Word*)
 - Under File use Open, Close, Save, Print
 - Under Edit use Undo, Spell Checker.
 - Use clipart and other graphics in word processor and spreadsheet

2. Perform a simple search for information bookmarked on the Internet.
3. Participate with class in an on-line project if a good one can be found or created.
4. Students will be able to login to the Windows server without adult assistance.
5. Students will be able to save to their network drive and access these files on other computers.
6. Be able to understand the basics of online safety and understand not to give out information without a parent.

Applications:

1. Save files they are working on to the network to be opened the following class.
2. Write a report or letter in correct form.
3. UltraKey
4. ReadNaturally
5. READ180 assistive technology

Fourth Grade

The student will:

1. Adjust type size, font, color and border.
2. On UltraKey touch type 15 words per minute with 85% accuracy.
3. Use Save As to save a document on the server.
4. In a spreadsheet with data already entered use "Sort," make simple calculations, and graph the information.
5. Participate with class in an on-line project if a good one can be found or created.
7. Students will be able to login to the Windows server without adult assistance
8. Students will be able to save to their network drive and access these files on other computers.

Applications:

1. Use a word processor to make final copies of major reports in any subject.
2. Demonstrate simple calculations such as mean, median, and mode on a spreadsheet.
3. Perform a search for information bookmarked by the teacher on the Internet. (For example, on the some aspect of the history of Michigan)
4. ReadNaturally
5. UltraKey
6. READ180

Fifth Grade

The student will:

1. Log on the Internet from desktop and use bookmarks to research an appropriate topic.
2. Perform a search on the Internet for information bookmarked by the teacher .
3. Paraphrase information and give credit to sources in making a report. Use quotation marks for direct quotes.
4. Type 18 words a minute on *UltraKey* with 90% accuracy.
5. Ask an appropriate question of an expert on a homework helper on Internet and report results to the class.
6. Use presentation software in *Microsoft Word* to make a class report.
7. Students will be able to login to the Windows server without adult assistance.
8. Students will be able to save to their network drive and access these files on other computers.
9. Students will be able to create folders, rename folders and delete folders

Applications:

1. As a class project report on class activities in newspaper format using *Microsoft Word*.
 2. Make any major report in other subjects on a word processor.
 3. Perform an Internet search for information on some question in U.S. History in sites bookmarked by the teacher.
 4. ReadNaturally
 5. UltraKey
 6. READ180
-

Sixth Grade

The student will:

1. Use teacher bookmarked sources to gather specified information.
2. Use the spreadsheet in *Microsoft Excel* to enter data, perform simple mathematical functions, and graph information.
3. Summarize and interpret results from spreadsheet and graph.
4. Type 20 words a minute on *UltraKey* with 100% accuracy.
5. Use presentation software in *Microsoft Word* to make a class report.
7. Students will be able to login to the Windows server without adult assistance.
8. Students will be able to save to their network drive and access these files on other computers
9. Students will create a presentation in Microsoft PowerPoint using hyperlinks, clipart, sound files, and digital photographs

Applications:

1. Use teacher bookmarked sources on the Internet to gather data and make a report on a foreign nation.
2. Word process major reports in other subjects.
3. Use quotation marks for direct quotes from digital or hard cover sources. Paraphrase information and give credit to sources in making a report.
4. ReadNaturally
5. READ180
6. UltraKey
7. Gaggle online Email use

Junior and Senior High School

In junior and senior high school the students have computer instruction in a lab setting. In both seventh and eighth grades students have either 9 or 12 weeks of computer instruction depending on the size of the class. In grades nine to twelve two semesters are required. Moodle, Prezi, Gaggle, EdOptions, Microsoft Word, Excel, PowerPoint, Access, Publisher and Paint are the programs used in both labs and classrooms. The major goal is to instruct students in the basic applications so they can use them as tools in other courses. Both labs have Internet access. In addition there is a lab in the library media center where students can work on projects for any class. All labs and classrooms use the same Microsoft application programs so there is no compatibility problem with typing part of a paper in one location and finishing it in another.

The computer classes in both junior and senior high seek common objectives that are defined in two ways.

1. A general set of objectives relates directly to the Michigan Content Standards.
2. A more detailed statement of performance objectives clarifies the general objectives and serves as the basis for evaluation of technology in the curriculum.
3. The completion of at least one online course as required for graduation.

Both sets of objectives are recorded below as composed by the two computer teachers.

General Objectives for Technology Instruction in Junior and Senior High School

The student will:

1. Improve keyboarding skills in a variety of advanced applications.
(Michigan Content Standard 4)
2. Develop ethical standards in using computer technology regarding content, copyright, patent, plagiarism, and Freedom of Information.
(Michigan Content Standards 1 and 2)
3. Reinforce skills on use of computers and printers.
(Michigan Content Standards 3 and 4)
4. Develop efficient skills in word processing.
(Michigan Content Standards 3 and 4)
5. Use a database program.
(Michigan Content Standards 3 and 4)
6. Use a spreadsheet program.
(Michigan Content Standards 3 and 4)

7. Use a paint or draw program.
(Michigan Content Standards 3 and 4)
8. Use a desktop publishing program.
(Michigan Content Standards 3 and 4)
9. Access information stored on CD-ROM disk.
(Michigan Content Standards 3 and 4)
10. Access information on a bulletin board system on the Internet.
(Michigan Content Standards 3 and 4)
11. Describe the influence of impact of computers on society (system on the Internet.
(Michigan Content Standard 2)
12. Describe emerging technologies and future expectations for technologies system on the Internet.
(Michigan Content Standard 5)
13. Use application software in conjunction with other subject areas.
(Michigan Content Standard 4 and 5)
14. Compile a portfolio of computer projects in junior and senior high courses system on the Internet.
15. Work singly and cooperatively to solve problems and complete computer projects system on the Internet.
(Michigan Content Standard 5)

Performance Objectives for Junior and Senior High School

Vocabulary

The student will:

- Define or match the following terms with definitions:
Keyboard, monitor, printer, modem, scanner, digital camera, graphics tablet, light pen, mouse, mousepad, chip memory (RAM, ROM, Bit, Byte, Kilobyte, Megabyte, Gigabyte,) special cards (Sound, Video, Memory), Input/Output network, network server, word processing, database, desktop publishing, telecommunications, programming, painting, multimedia CD-ROMs, diskette drives, hard drives, diskette, CD-ROM drive, file, file name, directory, ASCII format, import, export, format, save, open, close, exit, electronic mail, download, upload, bulletin board services, Internet provider, search, bookmark, hyperlink, navigator, browser, URL, WWW, HTML, keyword, site, pulldown menu, JAVA, homepage, icon menu, BASIC, bug, debug, program, cursor, DOS, Windows, hardcopy /print out, icon, menus, insert, delete, multimedia.

Word Processing

The student will:

1. Save, open, update, and print a document in *Microsoft Word*.
2. Change the text style (bold, underline, italic, font type and size).
3. Justify text (left, center, right, full).
4. Space text (single, double).
5. Spell check a document.
6. Use the proper format for a short essay assignment.
7. Add a page number in the footer of a multi-page document.
8. Automatically search for a word in a document and replace it with another word.

9. Use a computerized thesaurus.
 10. Use block features(copy, delete, move) in a document .
 11. Integrate two or more word processing documents.
 - 12.Export and import a document to an ASCII formatted file.
-

Spreadsheet Applications

The student will:

1. Load, save and update a spreadsheet document in *Microsoft Excel*.
2. Insert and delete data entered into a cell.
3. Format the content of a cell or range of cells (currency, number of decimal places).
4. Format the appearance of a spreadsheet (column width and height).
5. Use a spreadsheet as a mathematical calculator and create mathematical formulas using addition subtraction, multiplication and division symbols, and the SUM, MAX, and MIN functions.
6. Create a line, bar, and pie graph from the information in a section of a spreadsheet and add titles, legend and data labels to a graph.
7. Print an entire spreadsheet document.
8. Print a specific section of a spreadsheet document.
9. Print a graph generated in a spreadsheet document.

Paint or Draw Applications

The student will:

1. Create a diagram or picture in *Paint*
2. Save, load, update and print a painting/drawing document.
3. Use standard painting or drawing tools (paintbrush, line, rectangle, oval, polygon, spraypaint, zoom, capture).
4. Use copy, cut and paste features.
5. Integrate a painting or drawing into a word processing document.

Desktop Publishing Applications

The student will:

1. Integrate graphics and text in a desktop publishing program in *Microsoft Publisher*.
2. Save load, update, and print a document.
3. Import graphics from a paint/draw program into a desktop publishing document.

Telecommunications

The student will:

1. Describe the history of the World Wide Web.
 2. Use Internet appropriately following rules of the local "Acceptable Use Policy."
 3. Use quotation marks on quoted materials and give credit to sources.
 4. Paraphrase ideas and information carefully and if necessary give credit to the source.
 5. Distinguish between valid and questionable sources on the Internet.
 6. Pose search queries on the Internet so as to get a useful number of good responses.
 7. Download information from the Internet with understanding of the risks involved.
 8. Use email responsibly to communicate to staff and other students effectively.
-

E. Applying Technology to Other Subjects

One dimension of any course, (whether it is in science, math, language arts, social studies, art, music, physical education or any other subject area) is whether the use of more technology could improve the process of learning.

In every class the teachers should consider questions like these:

1. Are there sources of information in the digital world that are more conducive to learning some topics in this course than the traditional textbook and lecture?
2. Are there digital tools that would aid students to gain deeper insights into the subject matter and skills that are among the goals for this class? (Consider word processing, spreadsheets, databases, presentations, simulations, draw and paint programs, desktop publishing, Web pages, browsers, telecommunication).
3. Are there opportunities for electronic collaboration with people outside our school district that could give students in this course better understanding of the subject matter of the course?

Using technology in education has not proven superior to more traditional methods in any global sense. Sometimes it's better and often not. The challenge is to discover situations in which using technology offers an advantage and avoid situations in which it is a waste of time and money.

The following are examples that teachers have found useful in integrating technology into their curriculum:

*ReadNaturally Software: A software series that uses silent and read aloud tracking to increase fluency and comprehension in reading.

*Brain Pop Internet Site: Frankfort Elementary currently has a subscription to hundreds of movies available at www.brainpop.com. These movies come with a pre-quiz and activity sheets. These movies focus on the curricular areas of math and science.

*Video downloading from local ISD: TBAISD collaborates with United Streaming to provide over 2,000 videos to download and view in our district. Teachers are well versed in integrating these videos into their curriculum.

*Online web classes from EDOptions and Moodle

*In class use of projectors and document cameras to present material in a captivating format.

F. Staff Development

Technology is, and will continue to be a rapidly changing and increasingly influential force on the pedagogical framework of curriculum and the teaching/learning process. As such, teachers are and must continue to be the primary learners in our learning community. The cooperative ability of staff to make collaborative, effective use of the vast and exponentially growing sea of information will depend on the quality of the training and support.

An effort will be made to utilize staff meetings to meet with teachers to help them with the integration of technology into their respective teaching curricula.

1. 2012-2013
 1. The Technology Coordinator will provide mentoring and leadership to individual teachers regarding relevant integration of technology into the curriculum.
 2. The Technology Coordinator will provide opportunities for classroom visits to demonstrate the appropriate use of technology.
 2. 2014-2015
 1. The Technology Coordinator will mentor staff members to train others and be able to assist in the case that the coordinator cannot be there to assist.
-

G. Technical and Other Supporting Resources

Both the elementary and secondary schools have had several types of technical support in place. The Technology Coordinator will facilitate what support is used in what situation. The design and delivery of technical support will be in a fluid situation in the continued future for the school district.

Several staff members in each building including the media specialists and aides, some computer teachers, and office personnel are able to offer assistance with technical problems at times.

Some technical problems prove to be more than local personnel or consultant are able to deal with. In this case some technical problems are “out – sourced” to local technology companies who serve the school on a regular basis. These companies include:

- *Ascom – Telecommunications
- *Horizon Software – Food Service software
- *Dell – Hardware support
- *TBAISD – Doug Olsen, Head technology coordinator for the ISD
- *Netlink – Network troubleshooting

H. Goals and Evaluation

It is important that the district have goals and a measurable way of evaluating the achievement of these goals in our district. Information provided below explains what these goals are and how the school district will measure the progress towards meeting them.

The current technology goals of our district include the following:

- 1.) Increase student use of computers and web 2.0 applications
- 2.) Increase teacher use of computers and web 2.0 applications

- 3.) Increase technology integration into the current curriculum
- 4.) Take advantage of technology to ease everyday teacher duties such as grading and attendance.
- 5.) Utilize web-based software allowing for accessing attendance and gradebook software.
- 6.) Increase availability of staff training for the general use and maintenance of computers.

In recent years the Technology Coordinating Teacher and staff have addressed these goals and have made significant progress towards achieving them.

-The elementary school staff now uses PowerSchool to run attendance on, store staff files, store student files and share applications used by staff and students.(goal #5)

-Student applications and files are now more easily accessible creating more motivation to use the computers.
(goal #1)

-72 Latitude Netbooks have been added to the district to provide wireless access to all computer software and web access.

-The Technology Coordinating Teacher continues to address the staff needs for training and suggestions for the integration of technology. Examples of instructional classes include: the maintenance and upkeep of computers, how to organize, create and delete files, and how to save work to the network. This will become one of the top priorities for the upcoming school years.(goals #3, #6)

The staff will increase its use of computers in the coming years and continue to improve the integration of technology we currently have to better educate our students. They will also increase use time for both themselves and the students they teach. The use of the servers in both the Elementary and High School will need to be utilized more to take full advantage of their benefits.

An important change in the evaluation of teachers was made in the 1999-2000 school year when the negotiated master agreement between teachers and the district included “use of technology” in the annual evaluation process for professional staff. This data is then transferred to the evaluation table shown below. The rating scale will range from 1 to 10. One being the best and ten being the worst. Success will be determined by an increase in the rating given to the staff from year to year with a goal of 8 or higher by the year 2015.

In addition to the general “use of technology” evaluation, the percentage of time the computers and labs are used will also be added to the evaluation table. Teachers will be surveyed every six months as to the amount of time they and their students spend on the computers during a school day. The district will analyze these initial results and then look to improve the time spent integrating technology into the teacher’s classroom. Success will be measured by the increase of use in percentage from year to year. A certain percentage of use has yet to be decided in regards to what is deemed successful.

Lastly, the integration of technology into the curriculum will be measured in cooperation with the Technology Coordinator and school superintendent. This evaluation will be geared towards how the computers are used and the quality of the integration into the classroom. Are the teachers using the computers for games and drill activities? Or are they using the technology to enhance student learning and enhance their own methods of teaching in the classroom? The rating scale will range from 1 to 10. One being the best and ten being the worst. Success will be determined by an increase in the rating given to the staff from year to year with a goal of 8 or higher by the year 2015.

A review of the evaluations will determine if goals need to be re-addressed and additional work done. If this is the case the technology committee for the district will meet to discuss other possibilities in meeting these goals.

District Evaluation Table:

Evaluation	2011 – 2012	2012 – 2013	2013 – 2014	2014 - 2015
Percentage of week computers are used by teachers:				
Percentage of week computers are used by students:				
Rated Quality of Integrated Uses of Technology: (teacher average)				
Teacher Evaluation Rating: (teacher average)				

Student Evaluations:

With the heavy emphasis already placed on testing by the state, we do not want an evaluation program that devours a lot of class time or district money. At the same time we want valid and reliable evidence that students are learning what we claim to teach them. A major step now completed is the definition of technology goals in terms of what students should be able to do in each grade level. These performance objectives are presented in Section C. Using these, we will devise a procedure for testing annually a sampling of students at two or three grade levels in the K-12 sequence. For example, an objective for first grade is this: “The student will open a program like *First Grade JumpStart*, manipulate the program successfully with little or no teacher assistance and close the program.” A Study Island state aligned technology test will be given at the beginning of a school year and then again at the end of the school year . What percent of first graders could do this task? In fourth grade an objective is this: “The student will, on a word processor, adjust type size, font, color, and border.” What percent of a random sampling of students could do this?

In senior high school a series of objectives are these:

1. Load, save and update a spreadsheet document
2. Insert and delete data entered into a cell
3. Format the content of a cell or range of cells (currency, number of decimal places)
4. Format the appearance of a spreadsheet(column width and height)
5. Use a spreadsheet as a mathematical calculator and create mathematical formulas using addition subtraction, multiplication and division symbols, and the SUM, MAX, and MIN functions
6. Create a line, bar, and pie graph from the information in a section of a spreadsheet

An evaluation exam from the Study Island aligned state standards will be given to all 8th grades in the trimester that they take the technology rotation class.

I. Software

The software used in technology classes was identified in the earlier section on “Technology Curriculum.” Much of this same software such as word processing, spreadsheets and presentation programs carries over into the content areas. In addition, expository software designed for specific classes, is used by many teachers.

Administrative finance software has been consolidated with TBAISD. There is direct communication through networked

computers to keep track of financing and budget data.

PowerSchool is used in the elementary and secondary schools for student records, discipline records, scheduling, locker assignments, student group membership such as clubs and athletics, and state student accounting days. A component of PowerSchool, is used by teachers to record student attendance and grades. PowerTeacher assists teachers with progress reports, calculating grades and managing class information at the secondary level. The school lunch program is provided by Horizon Software. Students have used bar-coded I.D. cards since 1998 to purchase lunches. All of the record keeping and accounting for the lunch program is handled by this software program. In both elementary and secondary school buildings the *Libnet* program has replaced the card catalog in maintaining the library collections.

J. Hardware

2011 District Technology Inventory

- 95 desktop computers in high school (68 Deep Freeze/27 Symantec Endpoint)
- 48 netbook computers on two high school charging carts (all Deep Freeze)
- 87 desktop computers in elementary school (37 Deep Freeze/25 Symantec Endpoint)
- 25 netbook computers on elementary charging cart (all Deep Freeze)
- 6 3COM switches in elementary school
- 8 3COM switches in high school
- 1 Dell server in high school (used for apps and data for students and staff in both the ele and hs)
- 1 HP server in high school used for READ180
- 1 HP server in elementary school used for READ180 and ReadNaturally
- 24 HP Laser Printers in high school
- 4 HP 4600 color Laser Printers networked for student and staff use
- 25 HP Laser Printers in elementary school
- 2 HP 4600 color Laser Printers networked for student and staff use
- 20 Apple iPads with two charging carts (split between two schools)

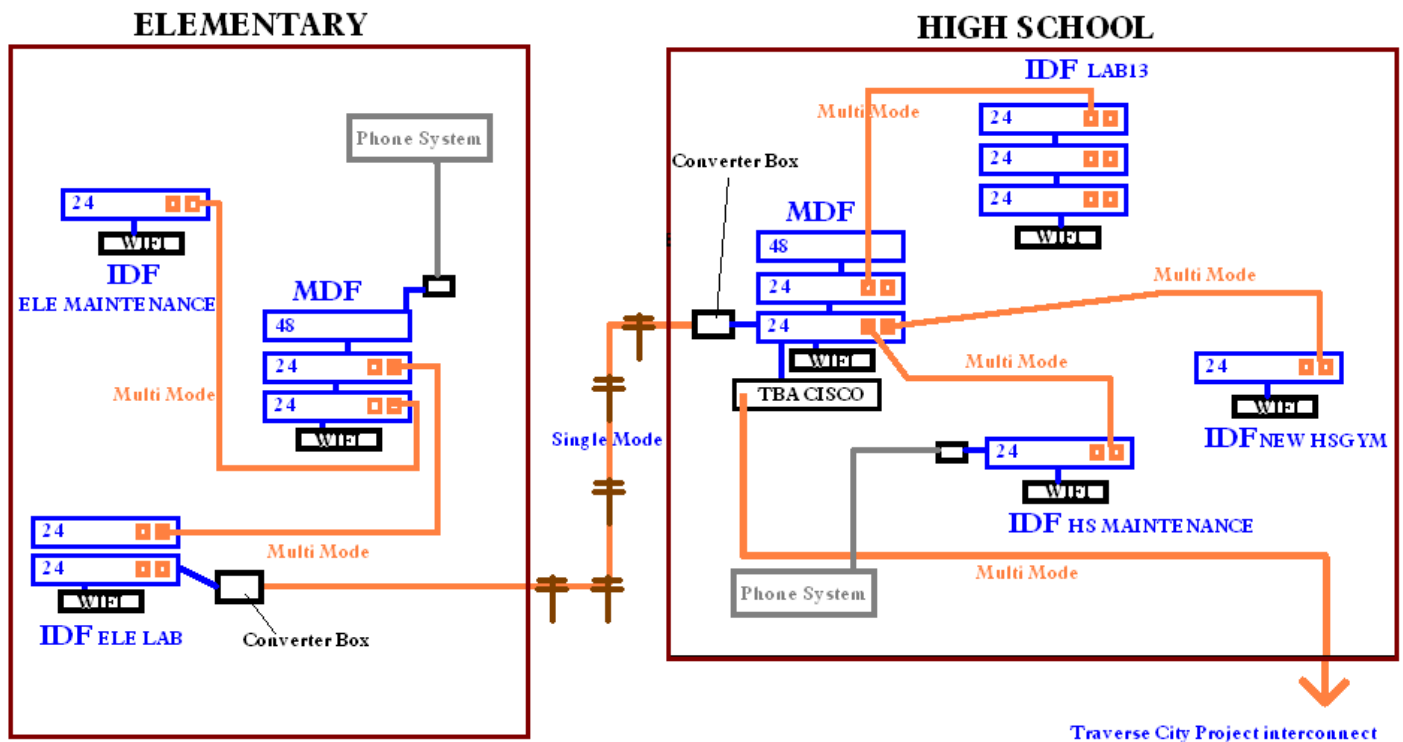

The district infrastructure has developed to the point where physical limitations are no longer the overriding factor. The district now has district-wide use of the Internet available in every classroom and a wireless infrastructure at both buildings. The schools also upgraded a T1 line to fiber in the spring of 2010. One major challenge is to refine the technology curriculum as presented earlier in this plan. Another challenge is the ongoing upgrading and replacement process as equipment becomes obsolete. The district used bond issue raised funds to provide almost all of the current infrastructure. Due to budget restraints, the district will have to investigate grant opportunities to continue with this upgrade.

The district currently has about one computer for every three students, far better than the state or national average. . All elementary and secondary classrooms are wired for voice, video, and data transmission.

Proposed Upgraded Equipment for 2012 USF funding:

These switches should meet or exceed the following specs:

Two 24 10/100BASE-T port switches

Nine 48 10/100BASE-T port switches

2 RJ-45 10/100/1000BASE-T ports (supports resilient stacking);
2 SFP slots for fiber media support;
Auto-negotiation for speed, duplex mode and flow control;
MDI/MDIX Port mirroring;
Broadcast storm control;
PoE feature;
Virtual Cable Tester™

Performance Switching capacity 12.8 Gbps;
Forwarding rate 9.5 Mpps;
Up to 8,000 MAC addresses

Management Web-based management interface;
Industry-standard CLI accessible via Telnet or Local Serial Port;
SNMPv1, SNMPv2c and SNMPv3 supported; four RMON groups supported (history, statistics, alarms, and events);
TFTP transfers of firmware and configuration files;
Dual firmware images on-board;
Multiple configuration file upload/download supported;
Statistics for error monitoring and performance optimization including port summary tables;
BootP/DHCP IP address management supported;
Syslog remote logging capabilities;
Temperature sensors for environmental monitoring;
LLDP and LLDP-MED; Switch stacking up to 8 units per stacking group.

Quality of service Layer 2 trusted mode (IEEE 802.1p tagging); Layer 3 trusted mode (DSCP); four priority queues per port;
Adjustable Weighted-Round-Robin (WRR), and strict queue scheduling

Security IEEE 802.1x based edge authentication;
Switch access password protection;
User-definable settings for enabling or disabling Web, SSH, Telnet, SSL management access;
Port-based MAC address alert and lock-down;
IP address filtering for management access via Telnet, HTTP, HTTPS/SSL, SSH and SNMP; RADIUS and TACACS+ remote authentication for switch management access; SSLv3 and SSHv2 encryption for switch management traffic; Management access filtering via management access profiles;
DHCP Snooping

VLAN VLAN support for tagging and port-based as per IEEE 802.1Q;
Up to 256 VLANs supported; Dynamic VLAN with GVRP support; Private VLAN Edge, Protocol VLANs, and Voice VLAN

Switching features Link aggregation with up to eight aggregated links and up to eight member ports per aggregated link (IEEE 802.3ad);
LACP support (IEEE 802.3ad)

Availability Spanning Tree (IEEE 802.1D) and Rapid Spanning Tree (IEEE 802.1w) with Fast Link Support; Multiple Spanning Trees (IEEE 802.1s)

Layer 2 multicast Static IP multicast;
IGMP snooping for IP multicast support

K. Interoperability

The compatibility of hardware and software is seriously considered in choosing hardware and software. All of the computers purchased in the district have been PCs and use the Windows operating system. The operating systems have not been always updated with each new release. Application software is not always immediately upgraded upon each new release either, but the district has made every attempt keep as current as funding will allow. This allows for students to have document portability when moving from workstation to workstation.

The district operates a Windows network. The district will need to continue to address the need to train the District Technology Coordinator to become a Windows certified network administrator available to serve the network needs of the district.

L. Community Relations and Parental Communications

Frankfort-Elberta Area Schools has used its technology to better communicate with its constituents (parents and students). The PowerSchool Attendance and Grading software encourages parents to keep track of all aspects of a students progress. Email functionality is encouraged with the software

The district web page lists important information and documents concerning the district. Some teachers have created web pages where parents can check student progress or review the teacher's lesson plans for the upcoming week(s). There is still considerable room for growth in this area and a chief strategy for accomplishing greater communication through technology will be to have the Technology Coordinating Teacher demonstrate and teach staff how to effective use technology to communicate with the district stakeholders.

M. Funding

Frankfort-Elberta Area Schools continues to seek additional funding through local, state, or national sources. These funding sources include, but are not limited to: grants, endowments, foundations, private sector donations, and gifts of equipment. While considering outside funding sources is of great importance, the district is committed to allocating a portion of its resources on an annual basis for the purpose of implementing and sustaining new technologies. The board and administration continues to seek input in the form of recommendation from the Technology Committee to coordinate combining the funds from outside sources with locally allocated funds.

Each year the Board of Education budget specifies an amount for technology instruction. A large source of funding for the technology currently in place has come from recent bond issues.

In 2003 the district was also awarded a grant of \$46,500 for the use of upgrading infrastructure, piloting wireless technology and funding an additional Learning Without Limits teacher through the TBAISD.

In the summer of 2004 the district received funds (\$10,000) from the Grand Traverse Band of Ottawa and Chippewa Indians Tribe and \$3,000 from the Frankfort Elberta Education Foundation for purchasing staff computers.

In addition to grants, the tech coordinator has also implemented an ongoing fundraiser by selling advertising to local businesses for restaurant placemats. This brings the district approximately \$6,000 per school year for the purchase of new staff computers.

In addition to our budget, we intend to supplement our school funding each year by applying to the Universal Service Fund. These services provide us with day to day essential operations and are not necessarily specifically shown in our technology plan. The district has participated in the Universal Service Fund program since its inception. No internal connection funds have been received, but the district gains positive results from telecommunication rebates. (refer to section J of this document)

We may request funding for the following services:

Telecommunications: local telephone services, long distance services, high speed access services (such as T-1, ISDN, Frame Relay, DID circuits, etc.), and cellular services.

Internet Access: internet access services including wireless, web hosting, and email services.

The reality of the funding sources over the next four years through 2015 is that any upgrading and replacement of equipment will have to come from monies raised outside of the general fund budget or through applications to USF.

N. Budget:

Existing and Projected Technology Budget:

The following chart is to be used as a guideline for future budgets and is meant to change with the priorities of the district. The District Technology Coordinator will continue to research and apply for grant funding with a goal of \$50,000 per year to be awarded.

	2011-2012	2012-2013	2013-2014	2014-2015
Software:	\$1,500	\$1,500	\$1,500	\$1,500
Licensing:	\$7,000	\$7,000	\$7,000	\$7,000
Support:	\$8,500	\$8,500	\$15,000	\$15,000
USF:	\$5,000	\$20,000	\$5,000	\$5,000
Hardware-Computers:	\$7,500	\$7,500	\$7,500	\$7,500
Professional Development	\$1,000	\$1,000	\$5,000	\$5,000
Grant Funding and Fundraising Efforts:	\$1,000	\$1,000 *projected amount	\$5,000 *projected amount	\$5,000 *Projected amount
Total:	\$23,500	\$23,500	\$41,000	\$41,000

O. Technology School Improvement Strategies for 2011-2015

1. Refine delivery of integration of technology into all classrooms.
2. Develop and implement student technical support team for assisting in district technology support.
3. Expand professional development opportunities for staff in the area of technology integration. \
4. Expand professional development opportunities for staff in the area of uses of iPads in the classroom.
5. Seek outside funding sources for additional technology and upgrades of existing technology.
6. Expand collaboration with community businesses and institutions around technology.
7. Expand use of distance learning opportunities including Moodle, EdOptions, Gaggle and other net based learning opportunities.
8. Continue to monitor the district's Internet filtering methods and acceptable use policies through annual review by the building and district technology committees.

Summary

The 2011-2015 version of the Frankfort-Elberta Area Schools District Technology Plan is an attempt to realistically update the vision of technology in the district. The need to constantly review and refine the processes in place within the institution regarding technology is acutely evident. The plan will continue to be reviewed through the organizational process in place within the district. The plan will be continuously referred to and considered as the district moves forward in the information age.